

Name _____

For 1 – 3, graph the function. Clearly show the vertex, axis of symmetry, and at least 2 other points.

1. $y = x^2 - 6x + 7$

2. $y = 2(x - 1)^2 - 4$

3. $y = -2(x - 4)(x - 2)$

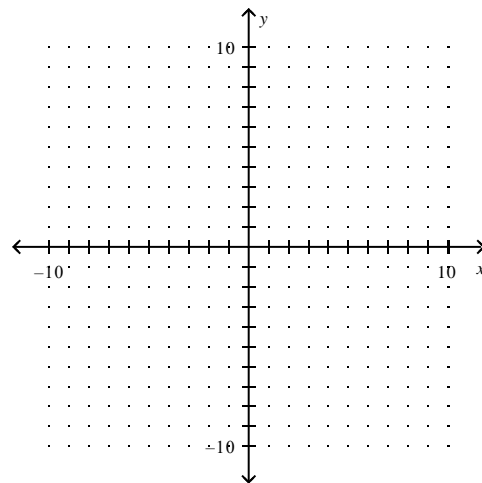
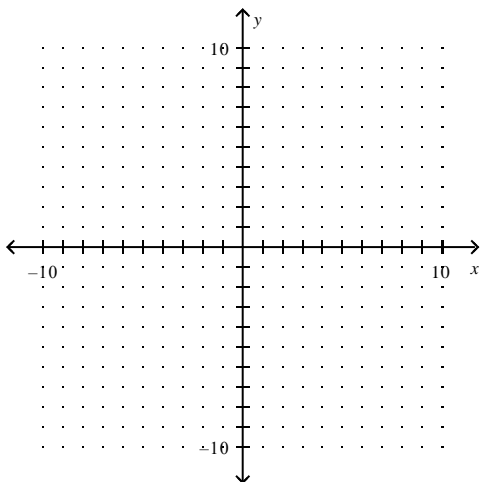
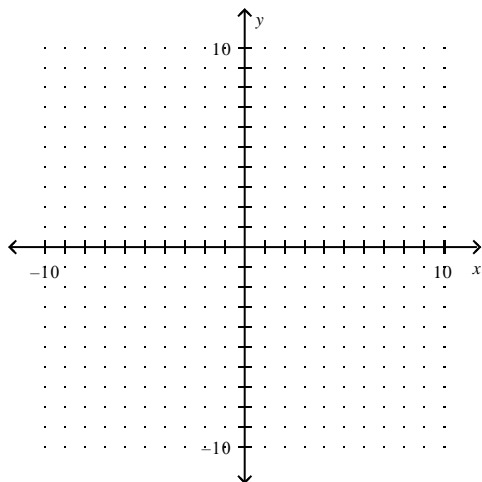

Solve by factoring and applying the zero product property.

4. $x^2 + 13x + 36 = 0$

5. $x^2 - 9x + 14 = 0$

6. $3x^2 + 5x - 28 = 0$

Solve by extracting square roots.

7. $(\frac{t+3}{2})^2 - 15 = 1$

8. $2x^2 - 54 = 18$

9. $7(x - 4)^2 - 18 = 10$

10. You have a picture that is 5 inches by 7 inches. You want to make a frame for the picture that is of uniform width. Together, the pictures and the frame have an area of 99 square inches.

Draw a picture to model the situation. Write and solve an equation to find the width of the frame.

11. A surfboard shop sells 45 surfboards per month when it charges \$500 per surfboard. For each \$20 decrease in price, the store sells 5 more surfboards per month. Write an equation to model the revenue as a function of x (the number of \$20 decreases.)

What is the maximum revenue? What is the “ x -value” that produces the maximum revenue? What price should they charge to create the maximum revenue?

12. For the period 1971-2001, the number y of films produced in the world can be modeled by the function

$$y = 10x^2 - 94x + 3900 \quad \text{where } x \text{ is the number of years since 1971.}$$

Make and label a sketch of your graph.

a.) What is the x value in the year 1981?

b.) Use your equation to find the number of films produced in the year 1981.

c.) In what year(s) were 4200 films produced?

d.) In what year(s) were 9000 films produced?